

REV.	ECN. NO.	APPD.
A	WL-21-006	Jerry zhang

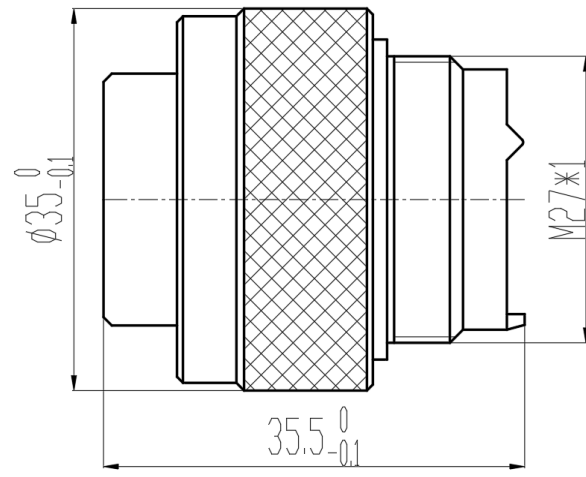

Technical Specifications

Operating temperature: -55°C - +200°C
 Relative humidity: 95% at 60°C ±2°C
 Sealing performance: immersion depth 0 ~ 55 meters
 Vibration: frequency 10-2000 Hz, acceleration 196 m/s²
 Shock: acceleration 980 m/s²
 Mechanical life: ≥1000 mating cycles
 Housing material: Stainless steel
 Contact parts: φ16, φ28
 Contact resistance: φ1 ≤ 5 mΩ, φ2 ≤ 1.25 mΩ
 Contact current: φ1 — 5A, φ2 — 20A
 Dielectric strength: 1500V at normal temperature

x.±	x.±	UNITS mm	NAME(INTENDED USE) 14-pin needle-type plug	CLASS: <input type="checkbox"/> CONFIDENTIAL <input type="checkbox"/> SECRET <input checked="" type="checkbox"/> GENERAL						
.x± 0.8	.x'±	MAT'L	PART NO.(INTENDED USE) WLES25-9501							
.xx± 0.50	.xx'±	SEE NOTES	APPD: Yuan. wu 03/14'21	TITLE: CONN DRAWING						
.xxx±	.xxx'±	FINISH	Q'TY	DWG NO.: WLES25-9501-0379						
			CHKD: Lei. wang 03/15'21	<table border="1"> <tr> <td>SCALE</td> <td>SHEET</td> <td>REV.</td> </tr> <tr> <td>N/A</td> <td>1/1</td> <td>A</td> </tr> </table>	SCALE	SHEET	REV.	N/A	1/1	A
SCALE	SHEET	REV.								
N/A	1/1	A								
			DRAW: Min. sun 03/16'21							

IDEAS GENERATED DRAWING. DON'T CHANGE BY HAND.